



SUN-BATT-5.12R



USER MANUAL

SUN-BATT-5.12R/BYD 100Ah Rack Mounted

Global Tech China Ltd, 3 Floor, Wai Yip Industrial Building,
171 Wai Yip Street, Kwun Tong, Kowloon, Hong Kong.

Tel: +852 2884 4318 Fax: +8522884 4816

www.sunsynk.com / sales@sunsynk.com



Table of Contents

1. TECHNICAL DATA	4
1.1. Appearance	5
1.1.1. Rack Mounted SUN-BATT-5.12R	5
1.1.2. Wall Mounted SUN-BATT-5.12R	6
1.1.3. Cabinet Mounted SUN-BATT-5.12R	6
2. PRODUCT OVERVIEW	7
2.1. Brief Introduction	7
2.2. Interface Introduction	7
2.2.1. Switch ON/OFF	7
2.2.2. LED Indicator Definition	7
2.2.3. CAN / RS485 Port	9
2.2.4. RS232 Port	9
3. INSTALLATION GUIDE	10
3.1. Checking Before Installation	10
3.1.1. Checking Outer Packing Materials	10
3.2. Checking Deliverables	10
3.2.1. Rack Mounted Accessory Deliverables	11
3.2.2. Wall Mounted Accessory Deliverables	11
3.3. Tools	12
3.4. Installation Requirements	12
3.4.1. Installation Environment Requirements	12
3.4.2. Installation Carrier Requirements	12
3.5. Installation Instructions	13
3.5.1. Dimensions	13
3.5.2. Installation Steps (Rack Mounted)	14
3.5.3. Installation Steps (Wall Mounted)	15
4. BATTERY POWER AND COMMUNICATION CONNECTIONS	17
4.1. Wiring Steps	17
4.2. Parallel Cascade Connection	18
4.2.1. Power Cable Wiring Instructions	18
4.2.2. Communication Cable Connections	18
4.2.3. Wiring Diagram for Parallel Cascade Connection	19

5. MAINTENANCE	20
5.1. Recharge Requirements During Normal Storage	20
5.2. Recharge Requirements When Over Discharged	20

1. TECHNICAL DATA

Performance	
Nominal Voltage	51.2 Vdc
Nominal Capacity	100Ah
Battery Energy ¹	5120 Wh
Charge Voltage	55.68~56.16Vdc
Discharge Voltage	45.6-56.16 Vdc
Nominal Charge/Discharge Current	50A
Nominal Charge/Discharge Power	2500W
Max Charge / Discharge Current	100A
Max Charge / Discharge Power	5000W
Short Circuit Current	350A
Communication	
Display	SOC status indicator, LED indicator
Communication	RS232, RS485, CAN
General Specification	
Dimension(W×D×H mm)	440×550×130mm
Weight (Kg)	49kg
Installation	Rack-Mounted, Wall-Mounted or Cabinet-Mounted
Working Temperature ²	-20°C ~ 60°C
Storage Temperature	≤25°C, 12 months
	≤35°C, 6 months
	≤45°C, 3 months
Operating / Storage / humidity	≤ 95%RH
Max Operating Altitude	≤ 2000m
IP Rating	IP20
Cell Technology	LiFePO ₄ , Lithium-ion Phosphate
Cycle life ³	6000 Cycles @ 80% DOD / 25°C / 0.5C, 60% EOL
Scalability	Max 8 batteries in parallel
Warranty	5 years
Standard Compliance	
Certification	UN38.3, IEC62619, IEC61000, UL 1642(cell) (more available upon request)
Ordering and Deliverable Part	
Product ordering part	SUN-BATT-5.12R Battery SUN-BATT-5.12R Power cable SUN-BATT-5.12R Parallel cable

PLEASE NOTE

Operating current derating according to cell voltage and battery temperature.

1. Test conditions: 100% depth of discharge (DoD), 0.2C rate charge & discharge at 25°C;
2. Charge/discharge derating occurs when the operating temperature from -10°C to 5 °C & 45°C to 55°C.
3. Condition apply. Refer to SUN-BATT-5.12R Warranty Letter

1.1. Appearance

1.1.1. Rack Mounted SUN-BATT-5.12R

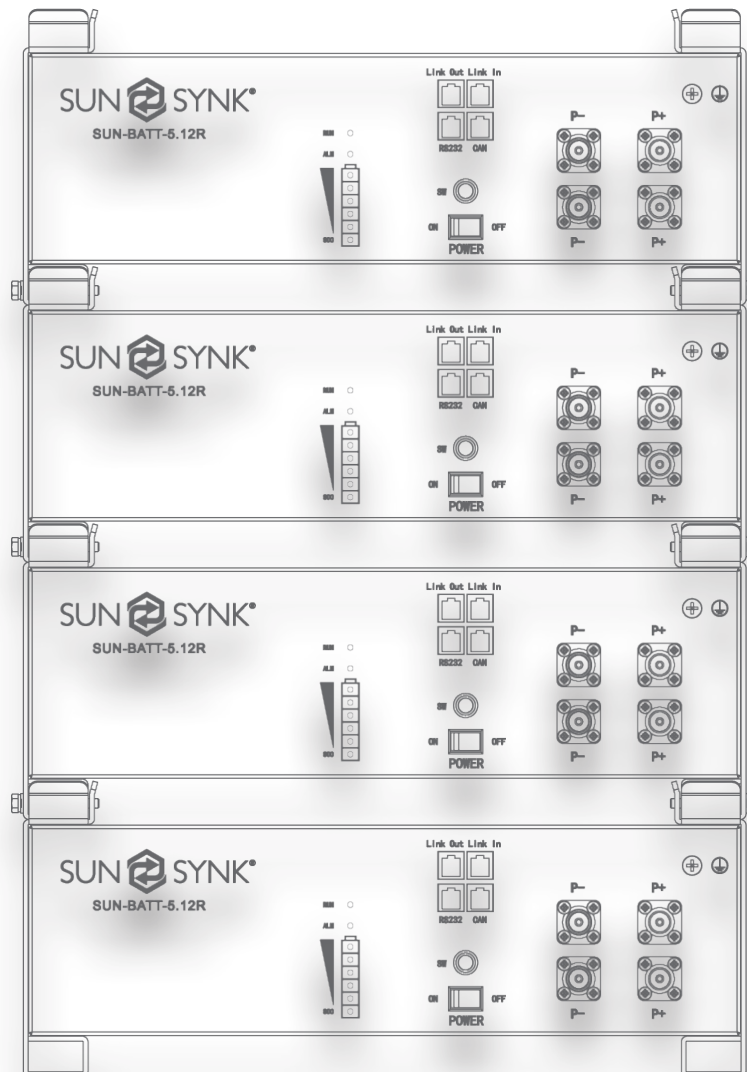

1.1.2. Wall Mounted SUN-BATT-5.12R

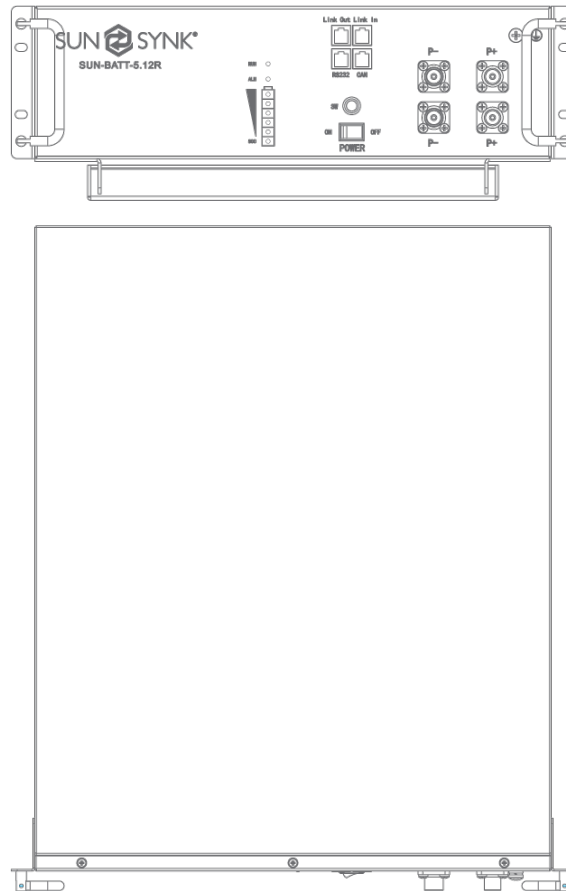

1.1.3. Cabinet Mounted SUN-BATT-5.12R

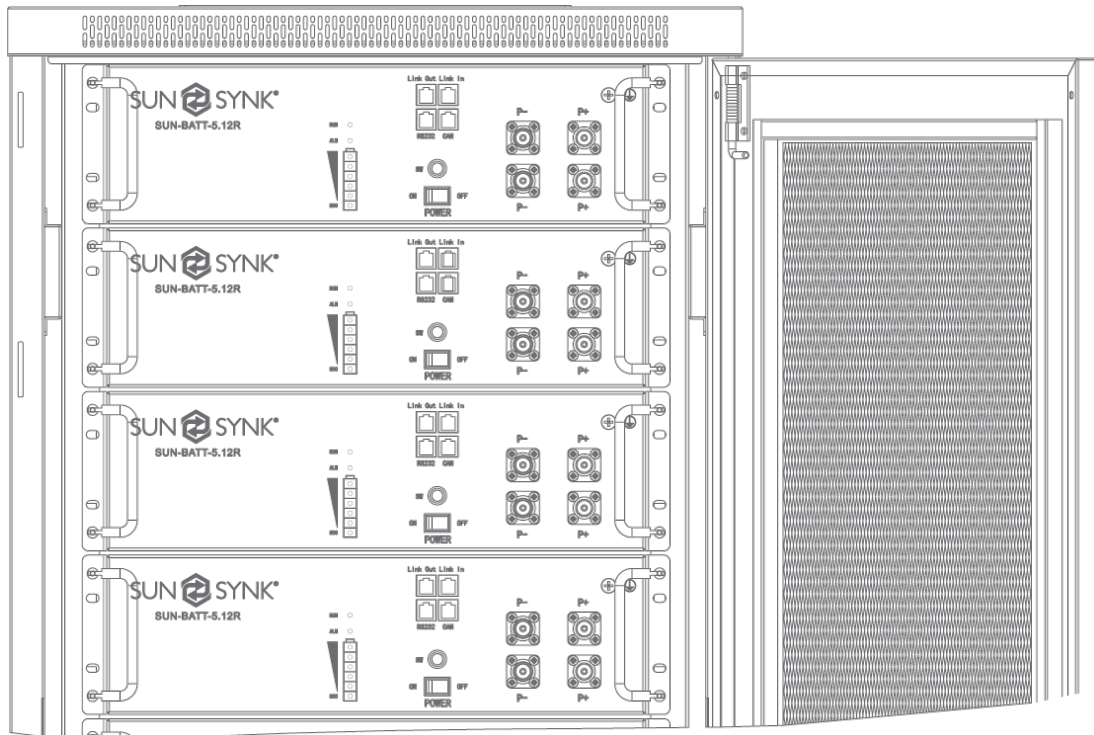

2. PRODUCT OVERVIEW

2.1. Brief Introduction

SUN-BATT-5.12R is a lithium battery with an operating voltage range between 45.6~56.16V. It is designed for residential energy storage applications and works together with a 48v battery hybrid inverter. SUN-BATT-5.12R is not suitable for supporting life-sustaining medical devices.

SUN-BATT-5.12R has built-in BMS (Battery Management System), which can manage and monitor cells information including voltage, current and temperature. Besides that, BMS can balance cells charging to extend cycle life. BMS has protection functions including over-discharge, over-charge, over-current and high/low temperature; the system can automatically manage charge state, discharge state and balance state.

Multiple SUN-BATT-5.12R can be connected in parallel to expand capacity and power, 8 SUN-BATT-5.12R can be connected in parallel at most.

2.2. Interface Introduction

2.2.1. Switch ON/OFF

Switch ON

For single SUN-BATT-5.12R, switch ON rocker switch, then long press (more than 3 seconds) ON/OFF button on front panel, LED will flash, then battery will operate normally. L1 to L6 shows battery SoC, L7/L8 shows battery status.

For multiple SUN-BATT-5.12R in parallel, switch ON rocker switch on all batteries, long press (more than 3 seconds) ON/OFF button of MASTER battery, LED will flash, battery system will automatically encode and assign ID to each slave battery, then battery system will operate normally.

Switch OFF

Press start button of Master PACK more than 3s and then release the button, the master pack will shut down after all slave packs shut down(Sleep mode).

For single SUN-BATT-5.12R, switch OFF rocker switch.

For multiple SUN-BATT-5.12R in parallel, switch OFF rocker switch on MASTER battery first. Then switch OFF rocker switch on all slave batteries

2.2.2. LED Indicator Definition

Note:

- flash 1 - 0.25s light / 3.75s off
- flash 2 - 0.5s light / 0.5s off
- flash 3 - 0.5s light / 1.5s off

Status		RUN	ALM	Battery Level Indicator						Discriptions
		L8	L7	L6	L5	L4	L3	L2	L1	
Shut down		OFF	OFF	OFF	OFF	OFF	OFF	OFF	OFF	All OFF
Standby		Flash 1	OFF	According to the battery level						Indicates Standby
Charging	Normal	Light	OFF	According to the battery level						The highest capacity indicator LED flashes (flash 2),others lighting
	Full Charged	Light	OFF	Light	Light	Light	Light	Light	Light	Turn to standby status when charger off
	Protection	OFF	Light	OFF	OFF	OFF	OFF	OFF	OFF	Stop charging
Dis-charge	Normal	Flash 3	OFF	According to the battery level						
	UVP	OFF	OFF	OFF	OFF	OFF	OFF	OFF	OFF	Stop charging
	Protection	OFF	Light	OFF	OFF	OFF	OFF	OFF	OFF	Stop discharge
Fault		OFF	Light	OFF	OFF	OFF	OFF	OFF	OFF	Stop charging and Discharge

Charging Battery Level Indicators Instructions:

Status		Charging							
Battery Level Indicator		L8	L7	L6	L5	L4	L3	L2	L1
Battery Level (%)	0 ~ 17%	Light	OFF	OFF	OFF	OFF	OFF	OFF	Flash 2
	18~ 33%			OFF	OFF	OFF	OFF	Flash 2	Light
	34 ~ 50%			OFF	OFF	OFF	Flash 2	Light	Light
	51 ~ 66%			OFF	OFF	Flash 2	Light	Light	Light
	67 ~ 83%			OFF	Flash 2	Light	Light	Light	Light
	84 ~ 100%			Flash 2	Light	Light	Light	Light	Light
	Full Charged			Light	Light	Light	Light	Light	Light

Discharging Battery Level Indicators Instructions:

Status		Discharge							
Battery Level Indicator		L8	L7	L6	L5	L4	L3	L2	L1
Battery Level (%)	0 ~ 17%	Flash 3	OFF	OFF	OFF	OFF	OFF	OFF	Light
	18~ 33%			OFF	OFF	OFF	OFF	Light	Light
	34 ~ 50%			OFF	OFF	OFF	Light	Light	Light
	51 ~ 66%			OFF	OFF	Light	Light	Light	Light
	67 ~ 83%			OFF	Light	Light	Light	Light	Light
	84 ~ 100%			Light	Light	Light	Light	Light	Light

2.2.3. CAN / RS485 Port

CAN / RS485 Communication Terminal (RJ45 port), connect to inverter, follow CAN / RS485 protocol.

PIN	Definition
Pin 1, Pin 8	RS485-B (to PCS, reserved)
Pin 2, Pin 7	RS485-A (to PCS, reserved)
Pin 3	NC
Pin 4	CANH (to PCS)
Pin 5	CANL (to PCS)
Pin 6	GND

2.2.4. RS232 Port

RS232 Communication Terminal (RJ45 port) follow RS232 protocol, for manufacturer or professional engineer to debug or service.

3. INSTALLATION GUIDE

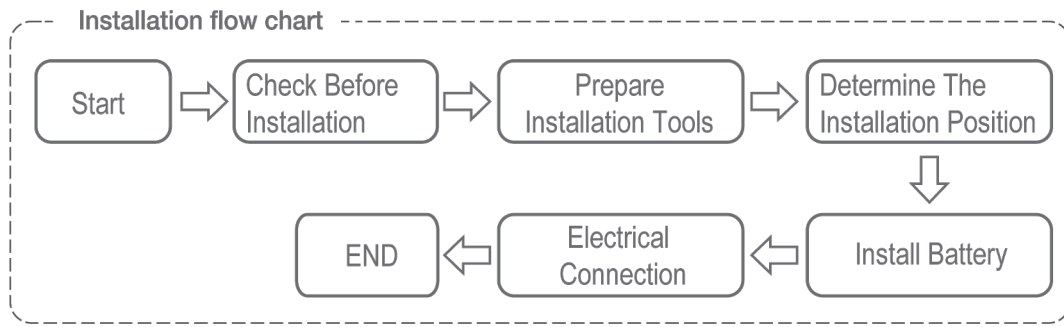

3.1. Checking Before Installation

3.1.1. Checking Outer Packing Materials

Packing materials and components may be damaged during transportation. Therefore, check the outer packing materials before installing the battery. Checking the surface of packing materials for damage, such as holes and cracks. If any damage is found, do not unpack the battery and contact the dealer as soon as possible. You are advised to remove the packing materials within 24 hours before installing the battery.



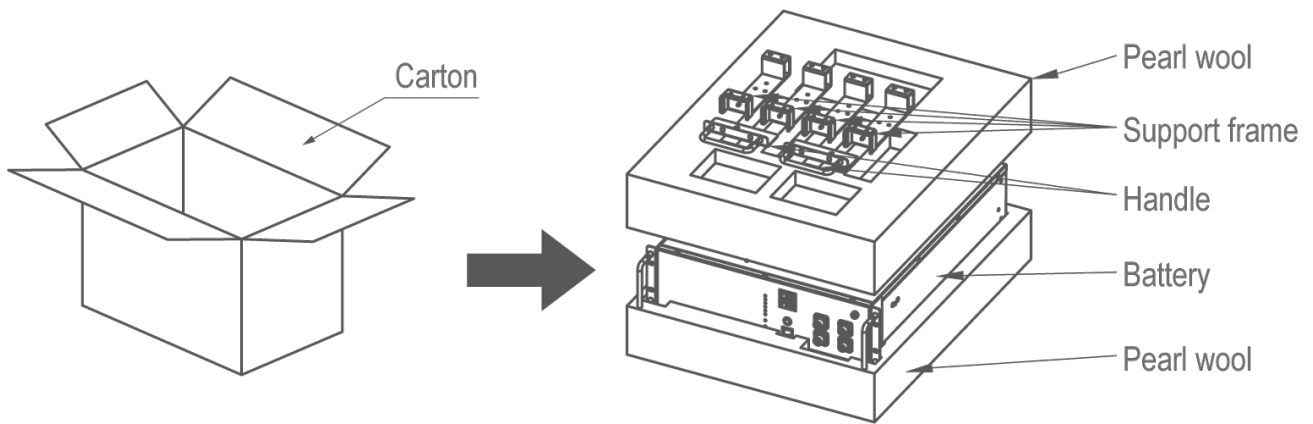

3.2. Checking Deliverables





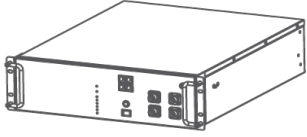
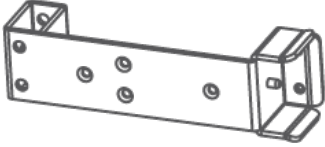

After unpacking the battery, check whether deliverables are intact and complete. If any damage is found or any component is missed, contact the dealer.

The below table shows the components and mechanical parts that should be delivered.



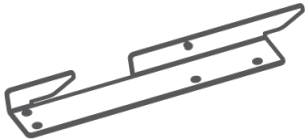



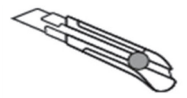
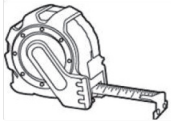

3.2.1. Rack Mounted Accessory Deliverables

NO.	Pictures	Quantity	Description
1		1PCS	Battery
2		4PCS	Support frame
3		12PCS	M4*8
4		8PCS	M6*50
5		1PCS	Manual
6		1PCS	Test report
7		1PCS	Certificate

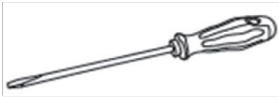
3.2.2. Wall Mounted Accessory Deliverables

NO.	Pictures	Quantity	Description
1		2PCS	Hanging bracket
2		1PCS	Wall bracket
3		4PCS	M8*60 Expansion bolts
4		2PCS	M4*20
5		8PCS	M6*16

3.3. Tools

Tools			
Installation	Knife 	Measuring tape 	Socket wrench (10/16mm) 
	Rubber mallet 	Cross Screwdriver 	Hammer drill (8mm) 
Protection	ESD gloves 	Safety goggles 	Anti-dust respirator 
	Safety shoes 		

3.4. Installation Requirements

3.4.1. Installation Environment Requirements

- Install the battery in the indoor environment.
- Place battery in secure location away from children and animals.
- Do not place the battery near any heat sources and avoid sparks.
- Do not expose the battery to moisture or liquids.
- Do not expose the battery to direct sunlight.

3.4.2. Installation Carrier Requirements

- Only mount battery on fire resistant building. Do not install batteries on flammable buildings.
- Battery is quite heavy, make sure the wall/ground can meet the load bearing requirements.

3.5. Installation Instructions

3.5.1. Dimensions

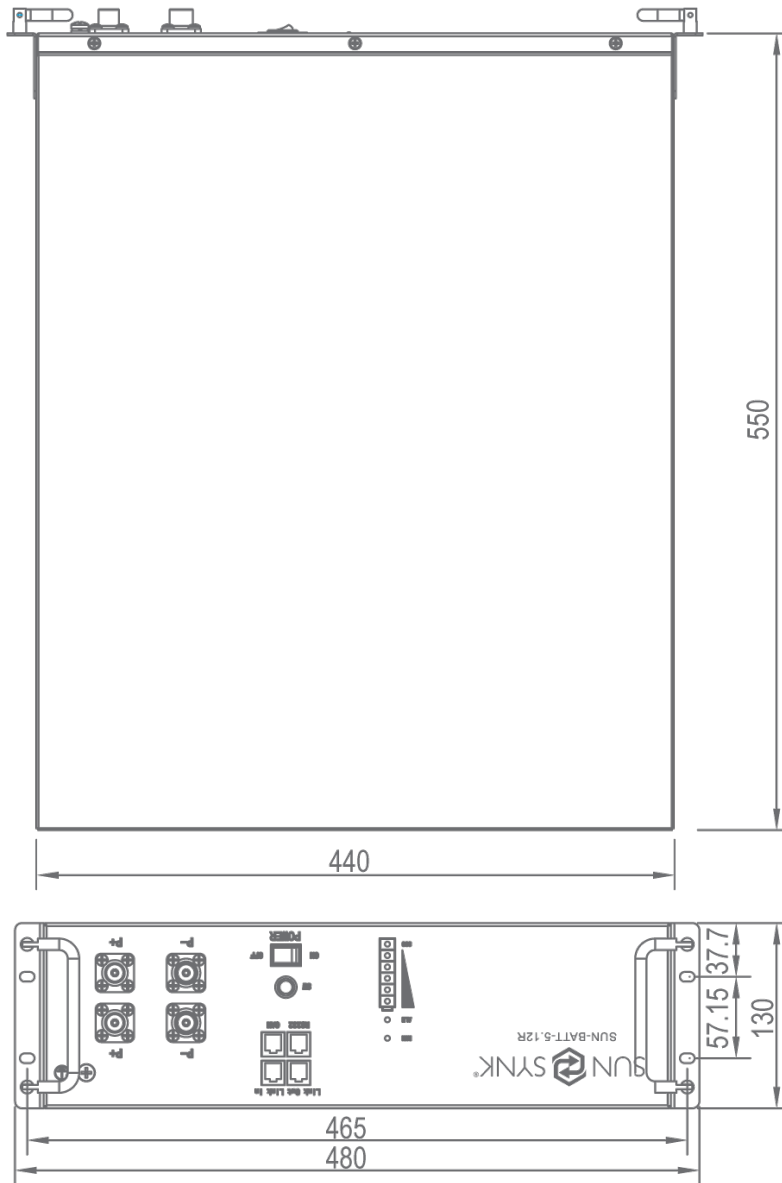

3.5.2. Installation Steps (Rack Mounted)

STEP 1

Remove the handle from the battery.

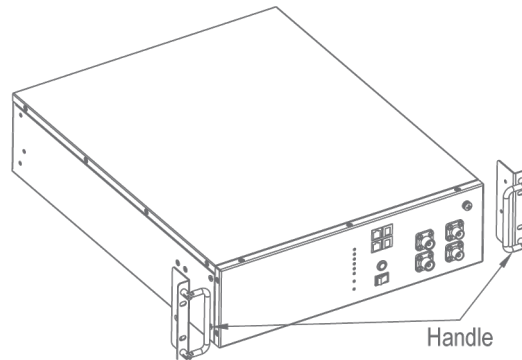

STEP 2

Install Support frames at the four corners of the battery.

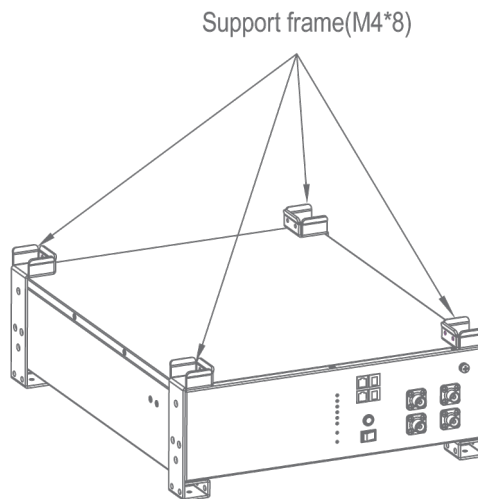

STEP 3

The battery with the support frame is stacked up and down.

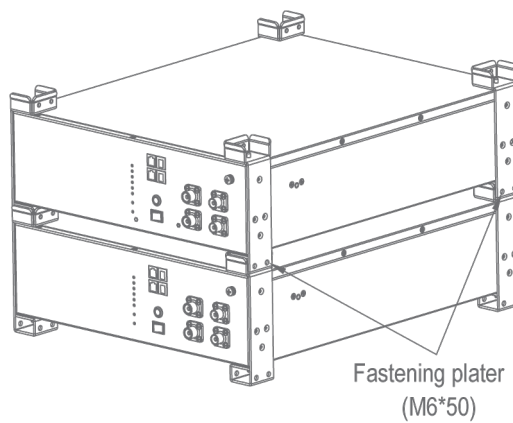

3.5.3. Installation Steps (Wall Mounted)

Minimum mounting distance requirement (Wall Mounted):

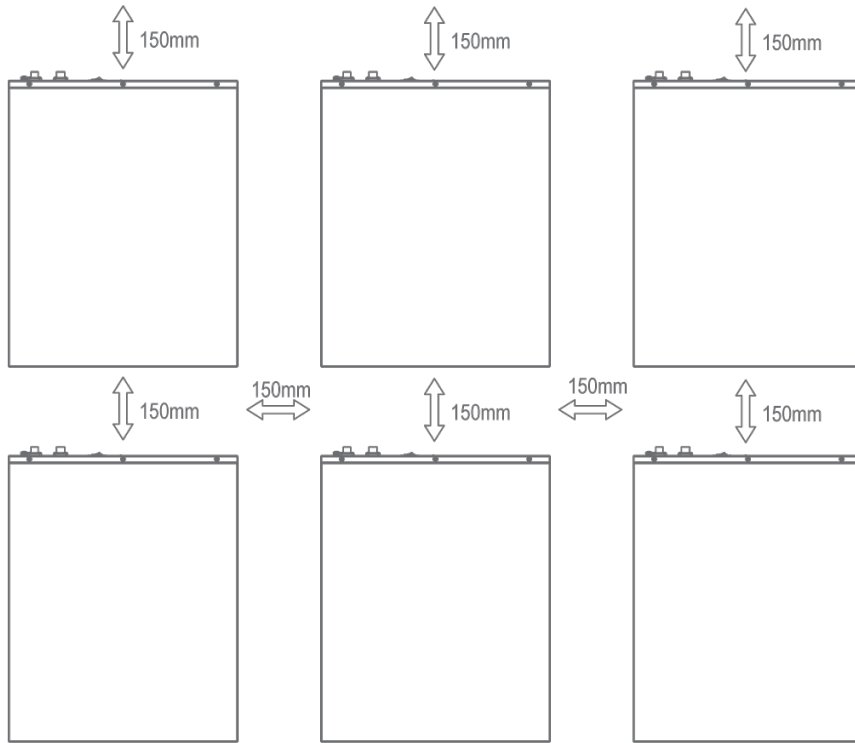

STEP 1

Drill the hole with an 10mm drill bit as follows and fix the wall bracket to the wall.

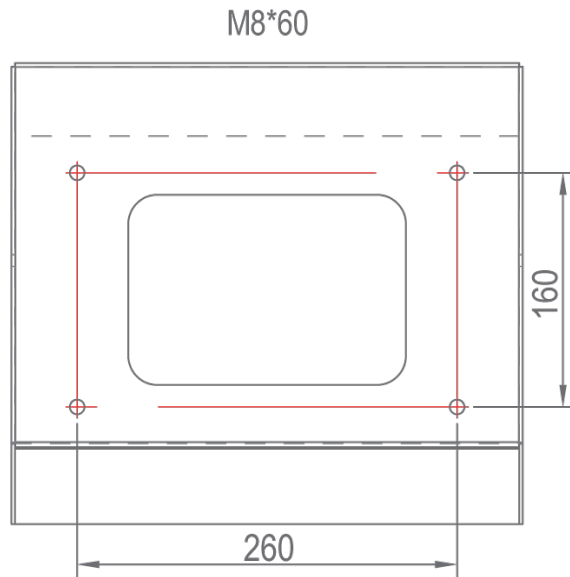

STEP 2

Install the wall hanging bracket.

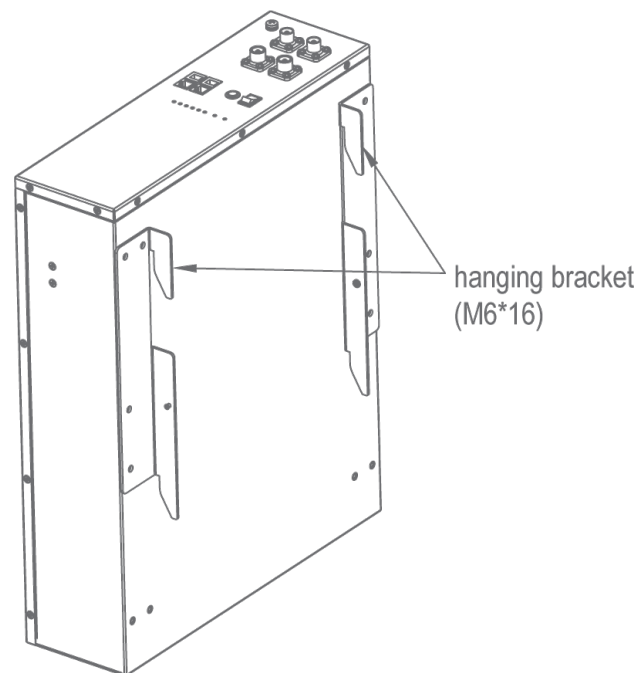

STEP 3

Hang the machine on the wall hanging back plate and tighten it.

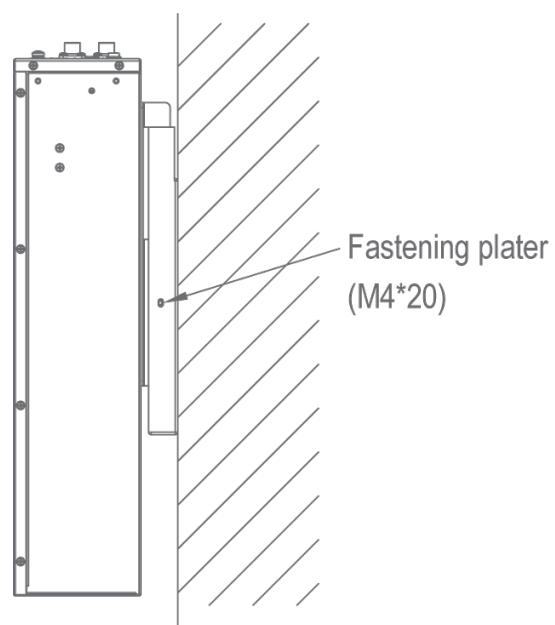

4. BATTERY POWER AND COMMUNICATION CONNECTIONS

4.1. Wiring Steps

STEP 1

Connect the battery to ground.

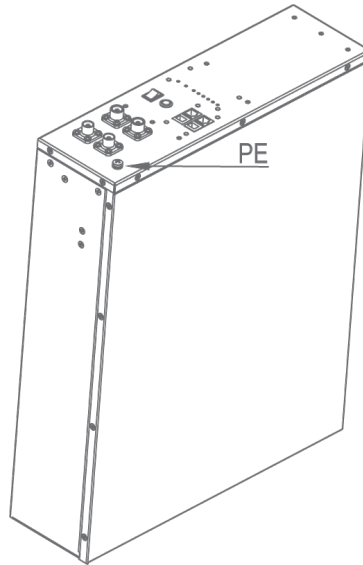

STEP 2

Connect the battery power line.

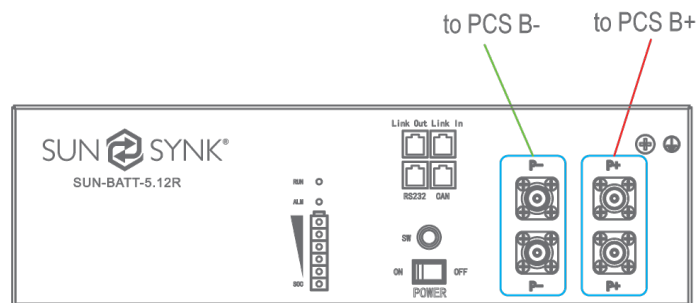

STEP 3

Connect the communication lines.

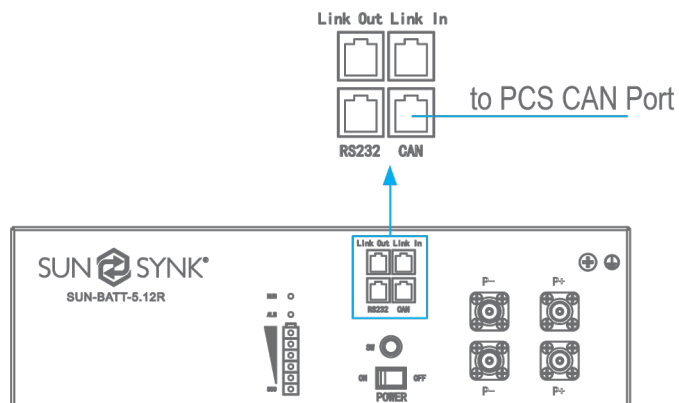

4.2. Parallel Cascade Connection

4.2.1. Power Cable Wiring Instructions

Each SUN-BATT-5.12R has two pairs of power cable terminals, two P+, and two P-. The connection terminals of each pair have the same function.

Single Module

In a single module application, any of the terminals of each pair can be used.

Parallel System

Multiple batteries can be connected in parallel to expand the capacity and power. When using multiple batteries in parallel, one will operate as a master and the others as slaves. One of the **Master** pack P+ terminals should connect to the PCS, and the other should connect to another battery for capacity expansion.

One of the P- terminals of the last **Slave** pack should connect to PCS, and the other should connect to another battery for capacity expansion.

For the other **Slave** packs, each P terminal should be connected to another battery's terminal.

PLEASE NOTE

The connection to the protection devices should use the P+ terminal from the Master pack and the P- terminal from the last Slave pack.

4.2.2. Communication Cable Connections

The Master battery can automatically identify the Slaves batteries connected in parallel using its internal software control. The communication terminals Port In and Port Out (RJ45 port) are integrated with the signal for automatic coding function.

The following describes the connections of a system with four batteries packs, one Master, and three Slaves.

- The **CAN** communication port of the **Master pack should connect to PCS**;
- Port In from the Master pack should not be connected;
- The Port Out from the master PACK should connect the Port In of the first slave PACK using a parallel communication wire;
- The Port Out of the first Slave pack should connect to the Port In of the second Slave PACK;
- Following the same pattern, the Port Out of the second Slave pack should connect to the Port In of the third Slave PACK;
- The Port Out of the third and last slave PACK should not be connected.

4.2.3. Wiring Diagram for Parallel Cascade Connection

When multiple batteries are connected in parallel, follow the following wiring mode.

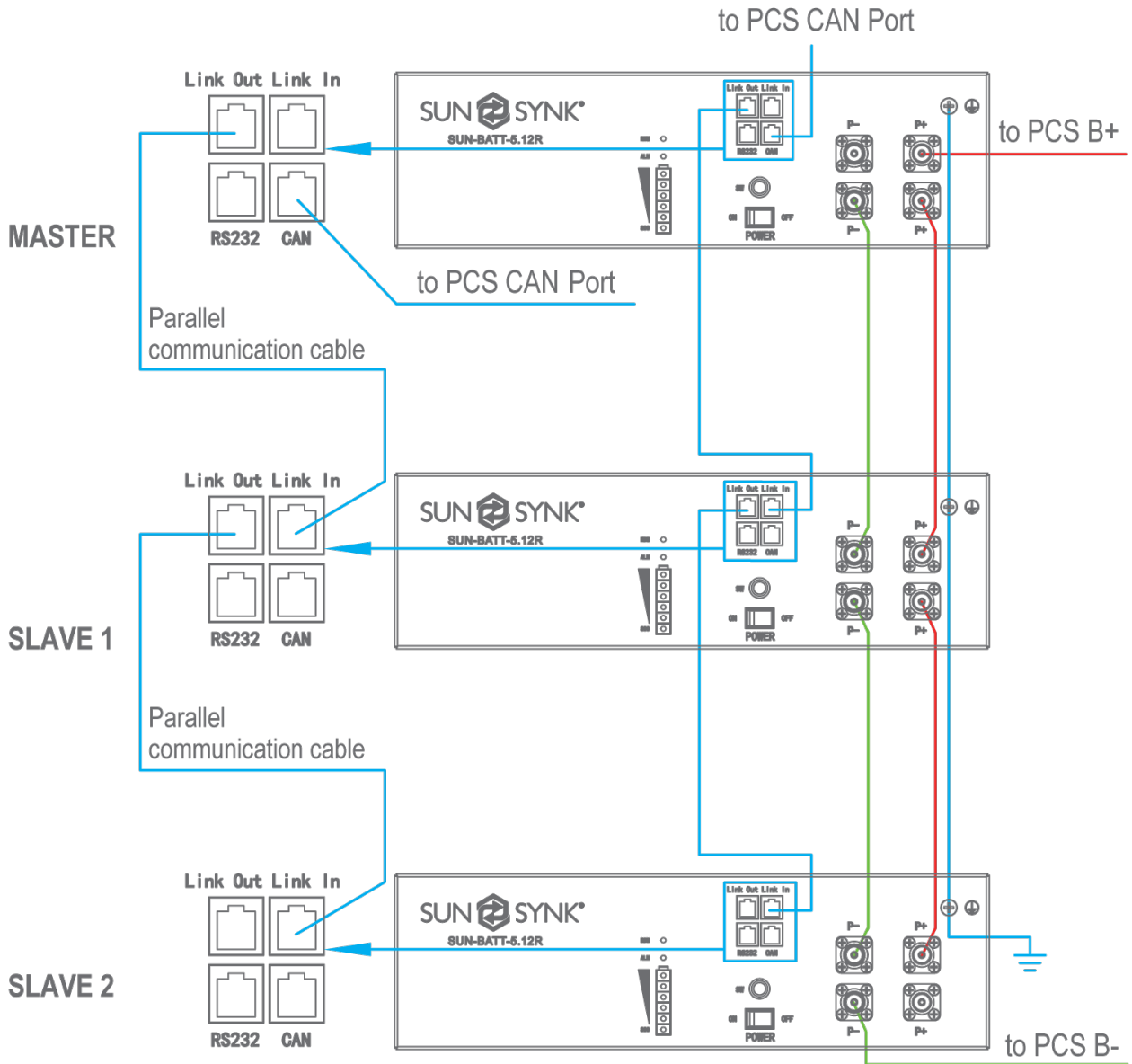

5. MAINTENANCE

5.1. Recharge Requirements During Normal Storage

Battery should be stored in an environment with temperature range between -10°C ~ $+45^{\circ}\text{C}$, and maintained regularly according to following table with 0.5C (25A) current till 40% SoC after long storage time.

Recharge Conditions When In Storage			
Storage Environment Temperature	Relative Humidity of Storage Environment	Storage Time	SOC
Below -10°C	/	prohibit	/
$-10\sim 25^{\circ}\text{C}$	5%~70%	≤ 12 months	$30\% \leq \text{SOC} \leq 60\%$
$25\sim 35^{\circ}\text{C}$	5%~70%	≤ 6 months	$30\% \leq \text{SOC} \leq 60\%$
$35\sim 45^{\circ}\text{C}$	5%~70%	≤ 3 months	$30\% \leq \text{SOC} \leq 60\%$
Above 45°C	/	prohibit	/

5.2. Recharge Requirements When Over Discharged

Over discharged (90% DoD) battery should be recharged according to following table, otherwise over discharged battery will be damaged.

Recharge conditions when battery is over discharged		
Storage Environment Temperature	Storage Time	Note
$-10\sim 25^{\circ}\text{C}$	≤ 15 days	Battery Pack disconnected from PCS
$25\sim 35^{\circ}\text{C}$	≤ 7 days	
$35\sim 45^{\circ}\text{C}$	< 12 hours	Battery Pack connected to PCS



CONTACT US

Email us: sales@sunsynk.com Call us UK: +44 151 8324300

VAT Number: 175669460

UK Address: Sunsynk, 17 Turnstone business park,
Mulberry Avenue. Widnes, Cheshire, WA8 0WN.

GlobalTech Ltd

